

# TACOMA BED STIFFENER BRACKET SET

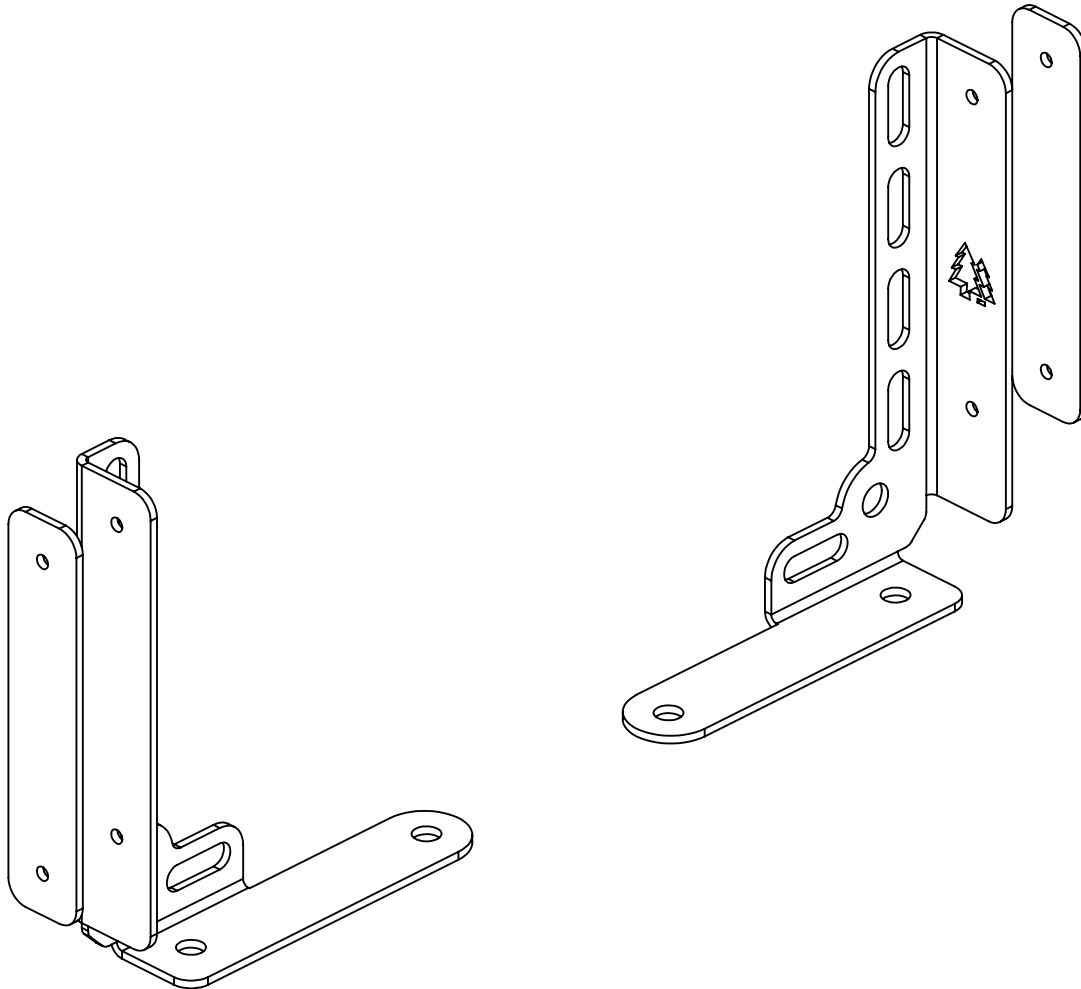

## INSTALLATION MANUAL



MADE IN CANADA

### DISCLAIMER

GreenLane Accessories is a division of Western Edison Manufacturing Corp. All of our products are designed for off-road use. Modify your vehicle at your own risk. By choosing to use our products you take full responsibility and liability for any resulting damages to persons or property. Designs are subject to change without notice. Your safety, and the safety of others is very important. CARELESS INSTALLATION AND OPERATION CAN RESULT IN SERIOUS INJURY OR EQUIPMENT DAMAGE. READ AND UNDERSTAND ALL SAFETY PRECAUTIONS AND OPERATING INSTRUCTIONS BEFORE INSTALLING AND OPERATING THIS PRODUCT.

### PROPRIETARY AND CONFIDENTIAL

THE INFORMATION CONTAINED IN THIS DRAWING IS THE SOLE PROPERTY OF WESTERN EDISON MANUFACTURING CORP. ANY REPRODUCTION IN PART OR AS A WHOLE WITHOUT THE WRITTEN PERMISSION OF WESTERN EDISON MANUFACTURING CORP IS PROHIBITED.

### DESCRIPTION:

## TACOMA BED STIFFENER BRACKET SET

### COMPATIBLE WITH:

2016+ TOYOTA TACOMA

### DATE UPDATED:

OCTOBER 2020



# TACOMA BED STIFFENER BRACKET INSTALLATION

**APPLICATION: 2016+ TOYOTA TACOMA**

<b>PARTS LIST</b>	
BED STIFFENER BRACKET L & R	1 Left, 1 Right
STAINLESS BACKING PLATE	2
5/16-18 NYLOCK, STAINLESS	4
5/16 WASHER, STAINLESS	4
5/16 WASHER, BLACK FINISH	4
5/16-18 X 1" BOLT, BLACK FINISH	4

<b>TOOLS REQUIRED</b>
T55 and T40 Torx Bits
Hammer
Center Punch & Pen/Pencil
Drill
3/8" Drill Bit (step bit will give best result)
1/2" Open End Wrench
3/16" Allen Key
Never-Seize or Blue Loctite

<b>TORQUE SPECS</b>		
<b>THREAD SIZE</b>	<b>HEX BOLT HEAD</b>	<b>TORQUE</b>
6mm	10mm	8 ft/lb
8mm	12 or 13 mm	18 ft/lb
10mm	17mm	23 ft/lb
12mm	19mm	50 ft/lb
14mm	22mm	90 ft/lb
1/4 in	7/16 in	12 ft/lb
5/16 in	1/2 in	19 ft/lb
3/8 in	9/16 in	23 ft/lb
1/2 in	3/4 in	90 ft/lb

**Instructions and images shown are for the *Driver Side* unit (bracket does not have tree logo).**

1. Remove the tail light from the truck by removing 2 of the 10mm bolts (see image); keep these bolts for later. Pull the tail light unit straight back to remove.



2. Remove two Torx bolts from bed – keep these as they will be re-installed.



3. The factory tie-down bolt will be disassembled and only the bolt, spacer, and lock washer will be used when re-installed.



4. Put the spacer and lock washer back in the hole they were in with the lock washer on top. Put the bracket in place on top of these.





5. Place the bracket and install with the two factory bolts in the floor of the bed loosely.



6. Hold bracket in place so that it is parallel with the edge of the box and mark the placement of the two side holes with a pen/pencil.

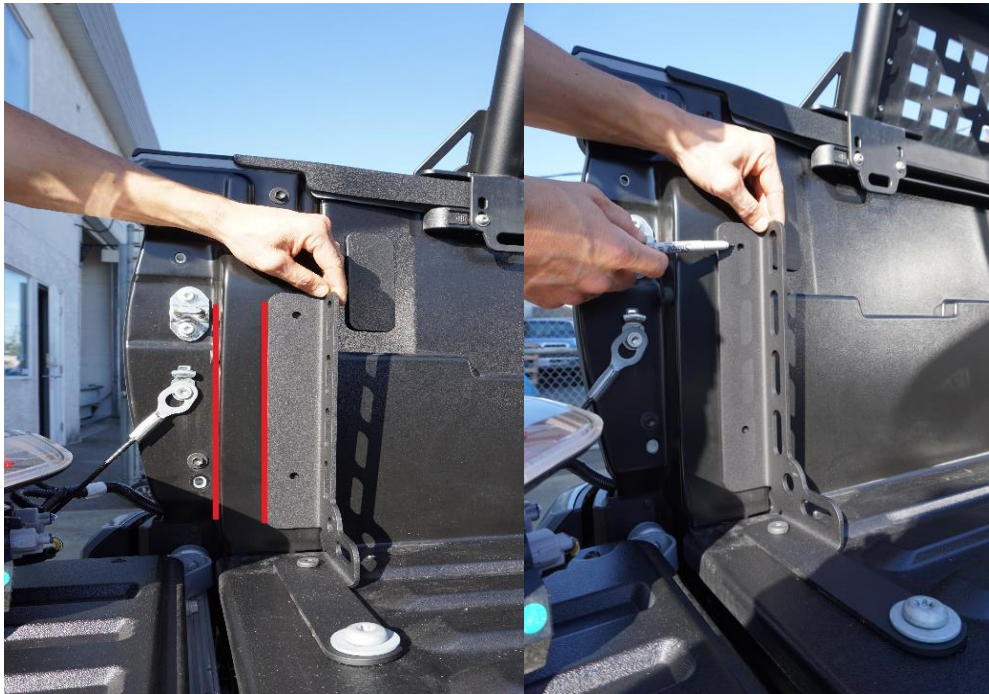

7. Remove the bracket and use a center punch to mark the holes.



8. Drill the two holes to 3/8" – using a step drill bit will give best results.



9. Put never-seize (or blue Loctite) on the factory bolts and reinstall with the bracket; do not tighten these bolts **yet**.



- Put never-seize (or blue Loctite) on the 5/16" bolts and install with the black flat washer through the holes on the side of the bracket and through the box.



- Install the backing plate (in tail light space) using the stainless washers and nuts.



12. **Snug** down Torx bolts on the floor of the bed.
13. Tighten side bracket bolts.
14. Tighten floor bracket bolts.
15. Re-Install taillight with the two 10mm fasteners.



Repeat all steps on the *passenger side* unit (bracket does have tree logo).

INSTALL COMPLETE